



Management Operations Control Applications (MOCA) Mission Update

AIAA Space 2016
Long Beach, California
September 13, 2016

Presented By:

Gary Pearce Barnhard, President & CEO
Xtraordinary Innovative Space Partnerships, Inc. (XISP-Inc)
gary.barnhard@xisp-inc.com
www.xisp-inc.com



The MOCA Mission

This body of work is an opportunity to craft viable technology demonstrations that will establish the basis for a confluence of interest between real mission users and the technology development effort.

This effort seeks to develop new tools to address N-Dimensional interaction problems (i.e., an arbitrary number of objects interacting in an arbitrary number of ways) which are a class of problems for which the generalized solution space is typically computationally intractable in any time frame.

This work can support a range of technology development missions on ISS and subsequent flight opportunities that can make efficient and effective use of near realtime state models and the enhanced Open MCT Web Software suite

Making It Real - 1

The order of the problem to be solved must be reduced to something tractable

- Breakup problem space into many sub-problems suitable for parallel processing
- Focus on the sub-problems that matter
- Use initial conditions, boundary conditions, symmetry, known geometry, established datums, etc. to further reduce complexity

The key is to propagate constraints as rapidly as possible

Making It Real - 2

- N-Dimensional interaction problems do not have to be intractable.
- With appropriate metadata, transforms can be applied.
 - *Data is a set of ordered symbols*
 - *Data in context is information*
 - *Information in perspective is knowledge*
- Problems of interest can be recast and structured as:
(Items(Attributes(Values))) -- LISP transform
- They can then be modeled as a set of process flow problems.
- Inference driven constraint propagation can then be applied to reduce the generalized solution space to a computationally tractable scale.

The structure and ordering of knowledge makes a very real difference . . .

Building Near-Realtime State Models . . .

- Systems-of-systems can be bounded as a finite set of state transitions
- Systems can be modeled as a set of flows across defined interfaces
- A taxonomy of flows can be defined as either energy, mass, or information and then further subdivided into individual types
- Each type of flow can be defined by a specific set of qualitative and quantitative attributes, independent of the source and terminus

Each set of characterized flows can be associated with corresponding states and allowable transitions.

Figure 10.
Sub-System “Flow” Taxonomy

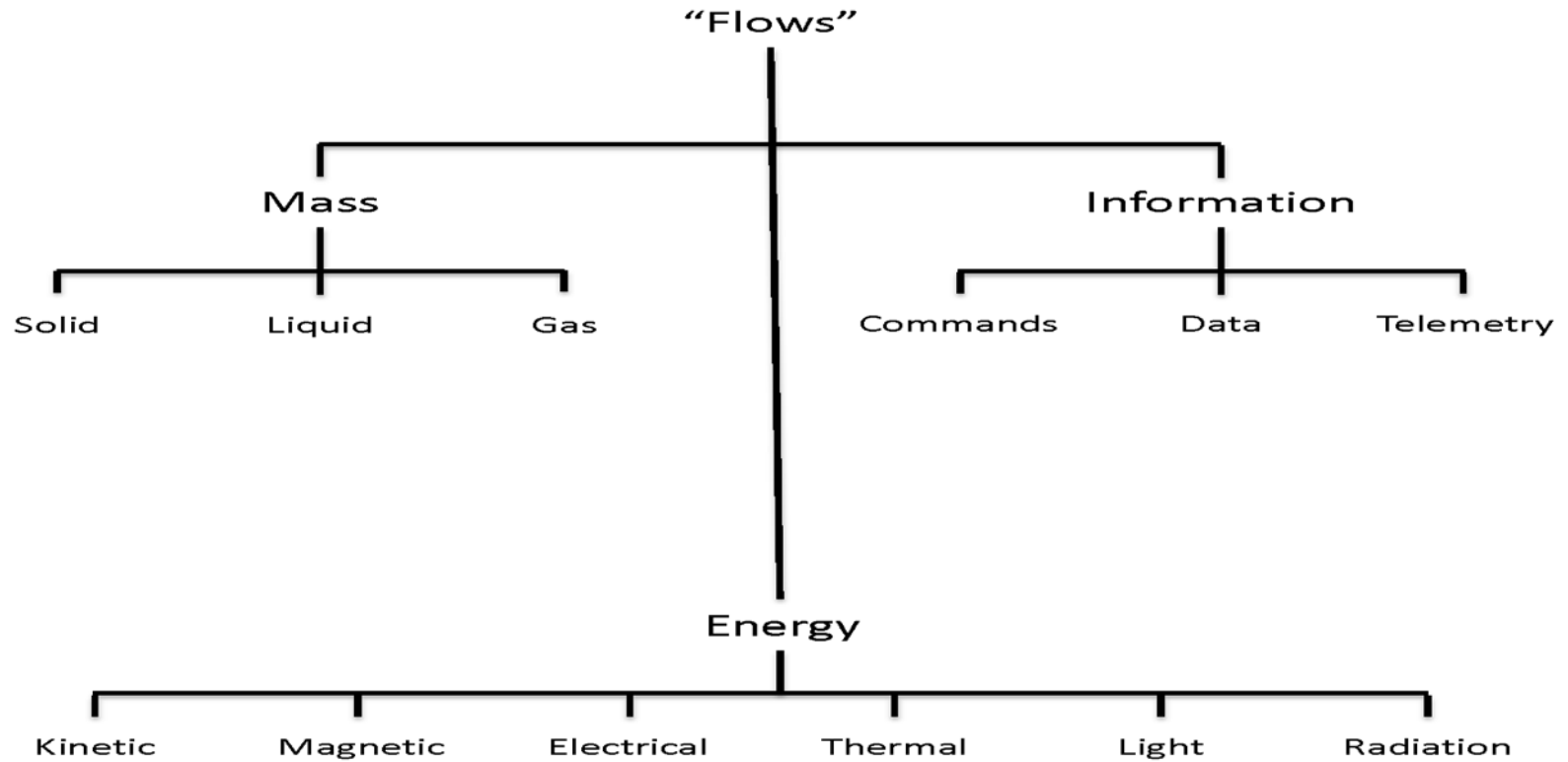

Relationship with NASA

- The NASA ARC Mission Control Technologies (MCT) Open MCT Web is the web based modular programming environment that is being enhanced by XISP-Inc to incorporate near realtime state model extensions.
- This work is germane to the NASA ARC / XISP-Inc Space Act Agreement on Management Operations Control Applications (MOCA) and an overarching Space Act Umbrella Agreement under negotiation between NASA Headquarters and XISP-Inc.

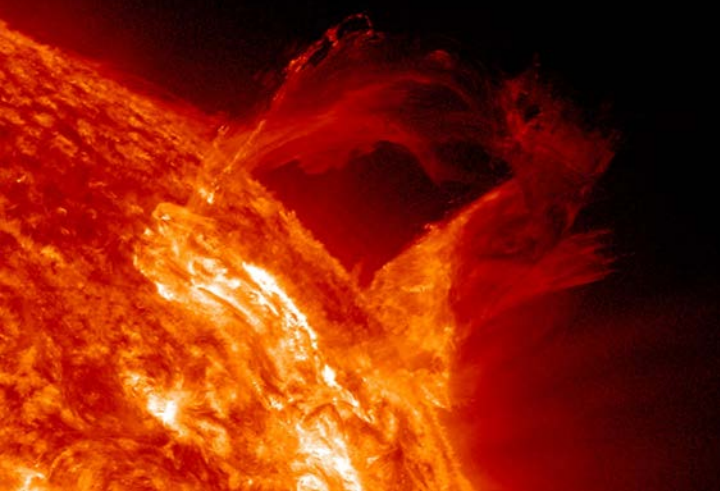

XISP-Inc MOCA Supported Missions

- **Team Alpha CubeSat (ACS) NASA Cube Quest Challenge**
 - Operations of 6U Cubesat
- **Space-to-Space Power Beaming (SSPB)**
 - Effective use of radiant energy beam components
- **Interoperable Network Communications Architecture (INCA)**
 - Testing DTN with real world requirements
 - Pervasively networked DTN gateway
- **Systems Control Through Advanced Algorithms (SCTAA)**
 - improve microgravity, decrease propellant use, and facilitate operations
 - Demonstrate adaptive control using state models
 - Multi-vehicle synchronization & payload control
- **Advanced Vision and Task Area Recognition (AVaTAR)**
 - Support mutable locus of control between teleoperation and autonomy on a shared control basis

MOCA Mission Initial Objectives

1. Defining and prototyping parametric state models for integrated end-to-end mission operations control applications.
2. Implementing the parametric state models for technology development and demonstration mission prototypes, test and flight articles.
3. This effort includes the incremental, iterative, and recursive development of near real-time state models of all the supported mission components operating within the MCT framework/environment

MOCA Initial Products for Supported Missions*

1. Development of a paper model and individual element protocode;
2. Development of functioning individual element models and an end-to-end model protocode;
3. Optimization of individual element models and a functioning end-to-end model;
4. Testing of the optimized end-to-end model and individual element models in mixed modes (protoflight hardware and software with simulation as needed).

** MOCA progress for each supported mission is being driven by the status and schedule of each mission and the availability of resources.*

MOCA Supported Mission Status

MOCA extended activities will focus on actual on-orbit demonstrations and flight testing the efficacy of the near realtime parametric state models developed for the supported missions.

Follow-on activities will focus on assessing, reviewing, and establishing the efficacy of applying the near real-time parametric state modelling tools to other current and future technology development missions.



XISP-Inc MOCA Supported Mission Status - 1

- **Team Alpha CubeSat (ACS) NASA Cube Quest Challenge**
 - NASA recognized team in good standing
 - Successfully completed PDR, pressing to CDR for this fall
 - Currently 95%+ volunteer effort supported by XISP-Inc
 - *System-of-systems view with drill down*

systems => subsystems => components => interfaces => flows

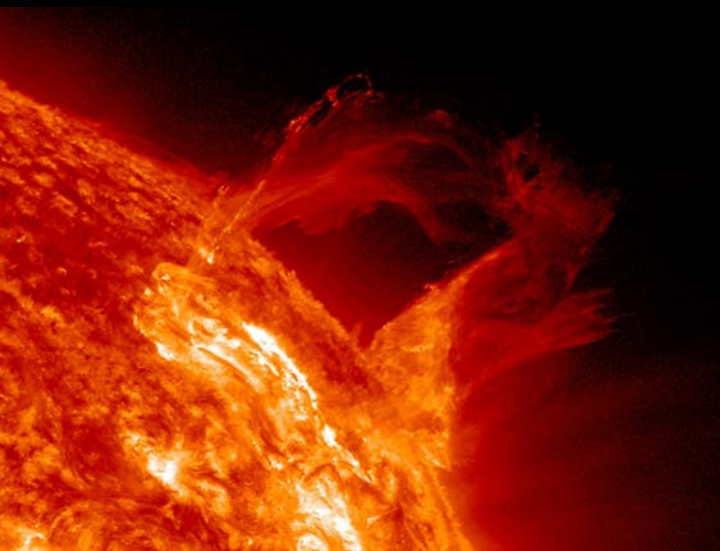

XISP-Inc MOCA Supported Mission Status - 2

- **Space-to-Space Power Beaming (SSPB)**
 - NASA recognized XISP-Inc commercial mission
 - Flight articles based on ACS & BitSat design from DSI
 - Public/Private implementation team forming up
 - CASIS integration support, Commercial Cargo, and ISS resource allocation requests in development
 - *End-to-end space-to-space radiant energy beaming characterization*

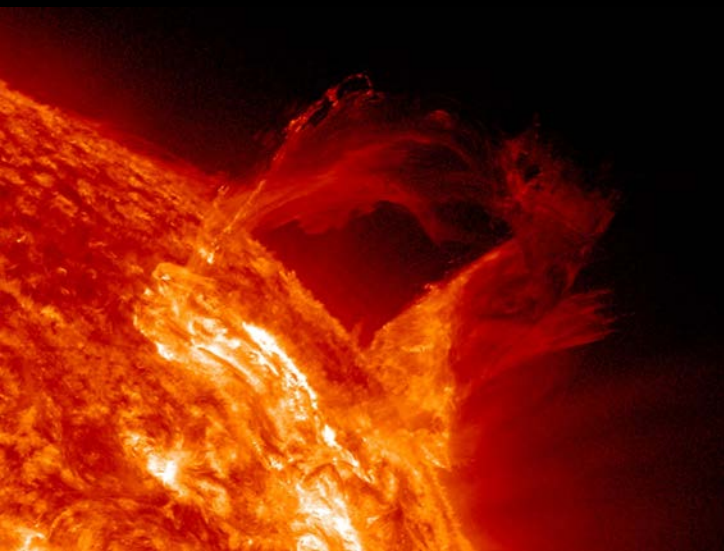

XISP-Inc MOCA Supported Mission Status - 3

- **Interoperable Network Communications Architecture (INCA)**
 - NASA recognized XISP-Inc commercial mission
 - Flight articles based on ACS & BitSat design from DSI
 - Public/Private implementation team forming up
 - CASIS integration support, Commercial Cargo, and ISS resource allocation requests in development
 - *Near realtime characterization of the Quality of Service (Performance, Availability, and Security) for a single defined function*

XISP-Inc MOCA Supported Mission Status - 4

- **Systems Control Through Advanced Algorithms (SCTAA)**
 - Ongoing technology development effort aligned with the NASA Payload Opportunities Program
 - EXOS Aerospace is an XISP-Inc teammate cooperating and collaborating on XISP-Inc missions (e.g., MOCA, SSPB, INCA, and AVaTAR)
 - *Near realtime state model of the star tracker data acquisition, state data processing, and Reaction Control System command string generation for precision pointing*

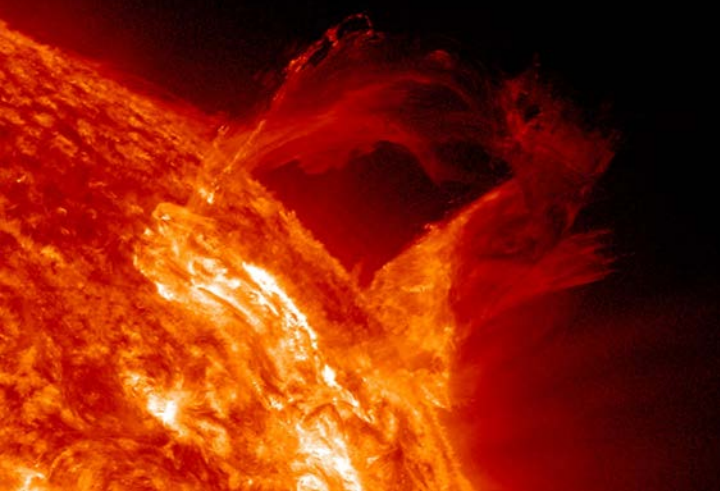

XISP-Inc MOCA Supported Mission Status - 5

- **Advanced Vision and Task Area Recognition (AVaTAR)**
 - Nascent mission opportunity which could leverage near realtime state modeling capabilities that meet real mission requirements as a foundational technology for evolving space automation and robotics capabilities.
 - *Near realtime state model of DEXTRE and dynamic world model of the task area and the it's intersection with the environment*

Enhanced MCT is intended to provide virtual control centers for all supported missions

Next Steps

- MOCA is now a commercial mission that will be worked with NASA through a combination of established and proposed Space Act Agreements.
- MOCA is intended to be a foundation for moving forward with the evolving XISP-Inc mission set
- Additional partners/participants are being sought in the commercial, academic, non-profit, and government sectors.
- Use of ISS helps ensure that this is an international cooperative/collaborative research effort.



Reality Check

- Reducing the number of perceived “impossible things that have to be accepted before breakfast”* is a way of incrementally disabusing people of unfounded notions.
- Doing something real with the technology that is of demonstrable value can help to establish the confluence of interests necessary to mature the technology for more advanced applications.



* Allusion to “Alice in Wonderland” by Lewis Carroll.
"Alice laughed: "There's no use trying," she said;
"one can't believe impossible things."
"I daresay you haven't had much practice," said the Queen. "When I was younger, I always did it for half an hour a day. Why, sometimes I've believed as many as six impossible things before breakfast."

Perhaps even run a starship?

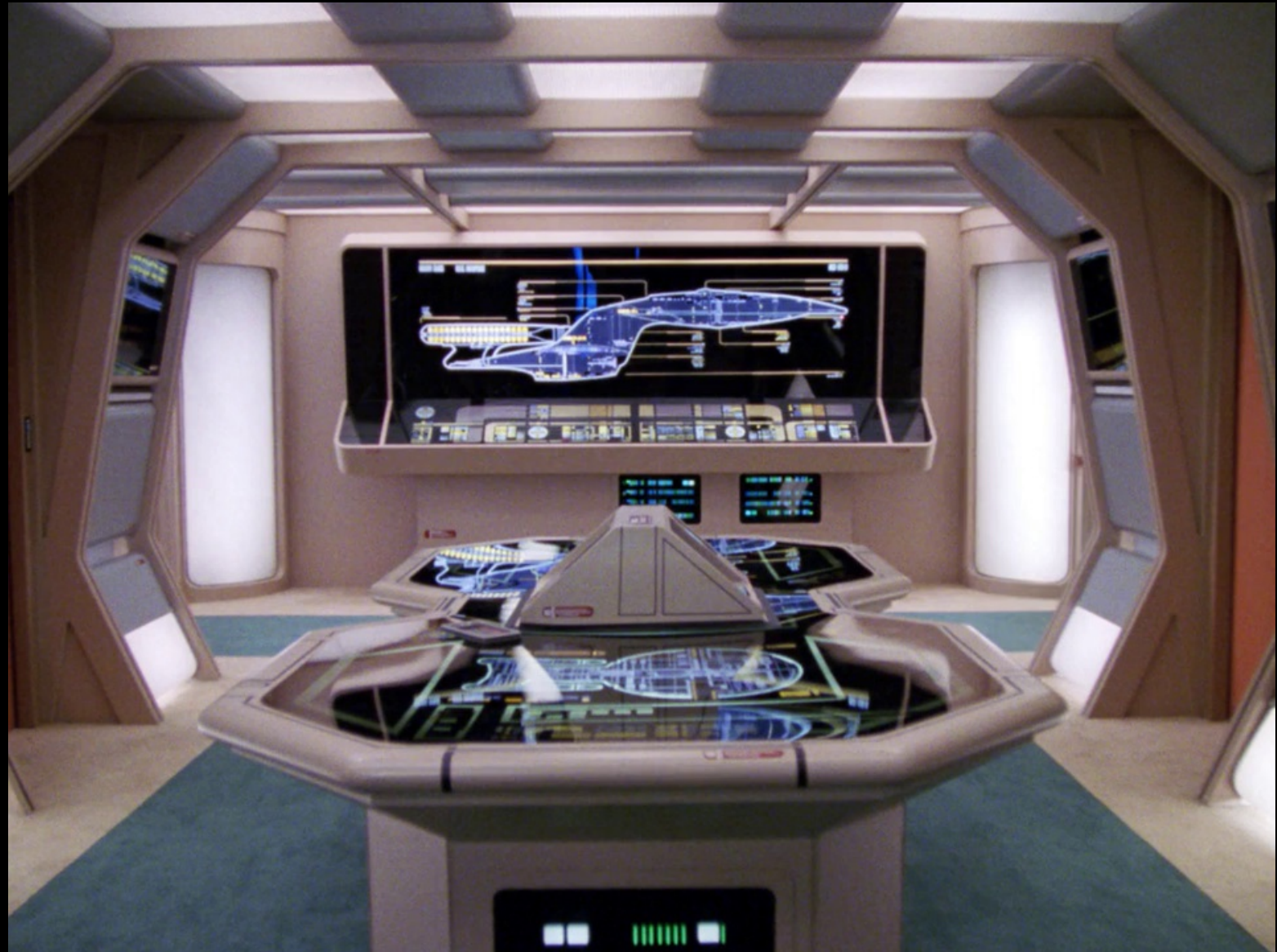

Conclusion

- An incremental investment in the development of near realtime state modelling capabilities that meet real mission requirements can serve as a foundational technology for evolving space automation and robotics capabilities.
- *This work can deliver:*
 - ➔ *Reduced cost, schedule & technical risk*
 - ➔ *Mission enhancing technology*
 - ➔ *Mission enabling technology*

Backup Charts

- Outline
- MOCA Mission Milestone Chart
- MOCA/Supported Mission Papers and Presentations
- MOCA Deliverables Schedule
- ACS Screen Shot Mockups
- AVaTAR Problem Space Pictures

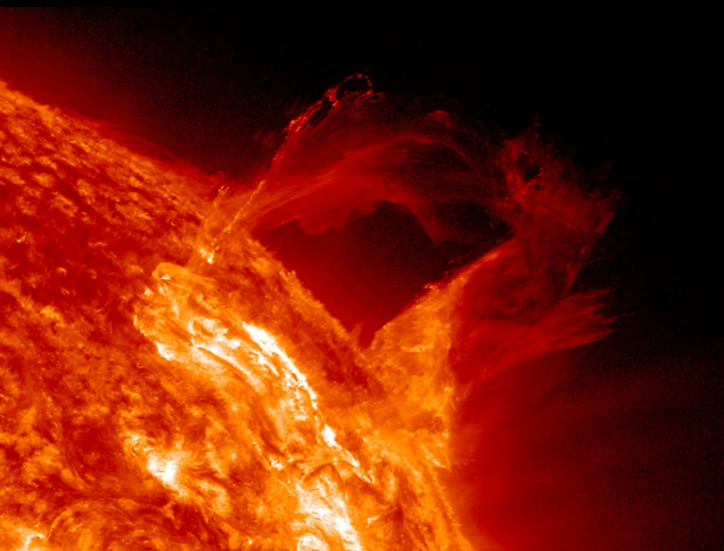

Outline

- The MOCA mission
- Making it real . . .
- Building near realtime state models
- Relationship with NASA
- Relevance
- XISP-Inc MOCA Supported Missions
- Next Steps
- Reality Check
- Conclusion

MOCA Mission Milestone Chart

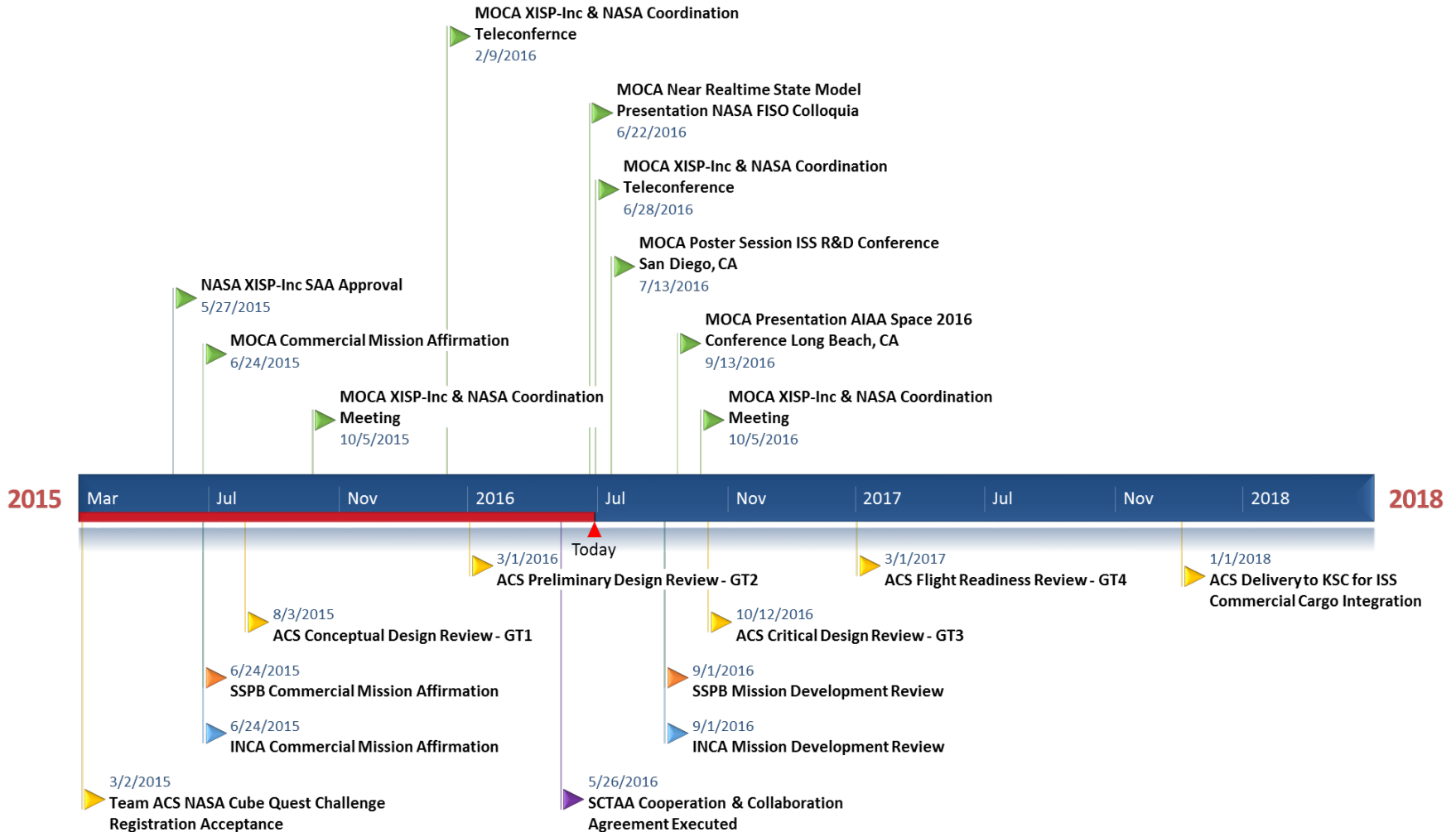

MOCA/Supported Mission Papers and Presentations

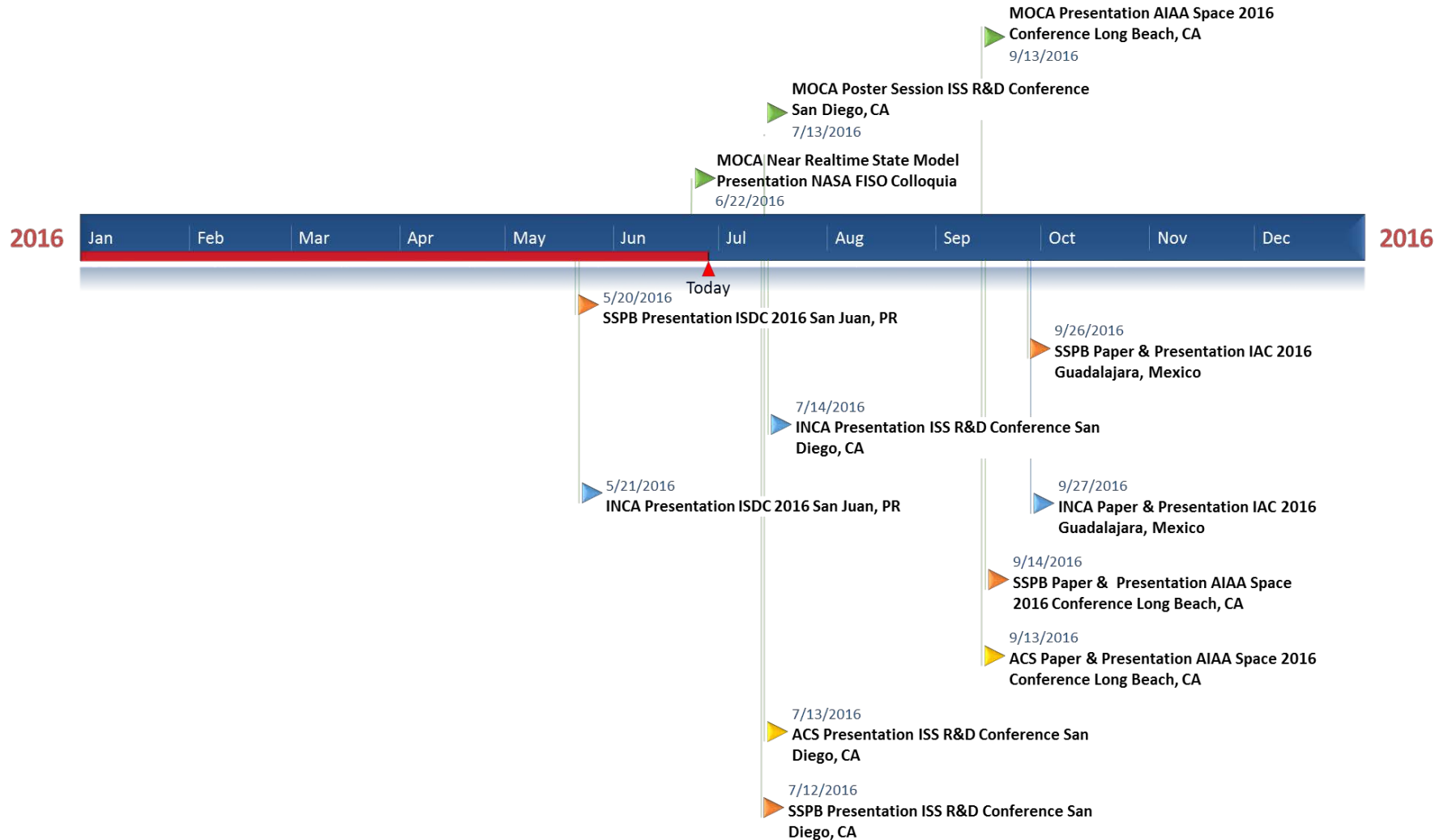

MOCA Deliverables Schedule

XISP-Inc/NASA MOCA Coordination Meeting (Quarterly)

- Near realtime state model extension code package
 - *Since the development of near real-time state models of the supported mission components operating within the MCT framework/environment is inherently an incremental, iterative, and recursive development process XISP-Inc will share both our successes, failures, including our analysis of the same.*
 - SCTAA MCT Extension Demonstration
 - SSPB MCT Extension Demonstration
 - INCA MCT Extension Demonstration
 - ACS MCT Extension Demonstration

**All MCT Extensions work will follow the defined MOCA Initial Products for Supported Missions Outline (see Page 11)*

EVA Robotics

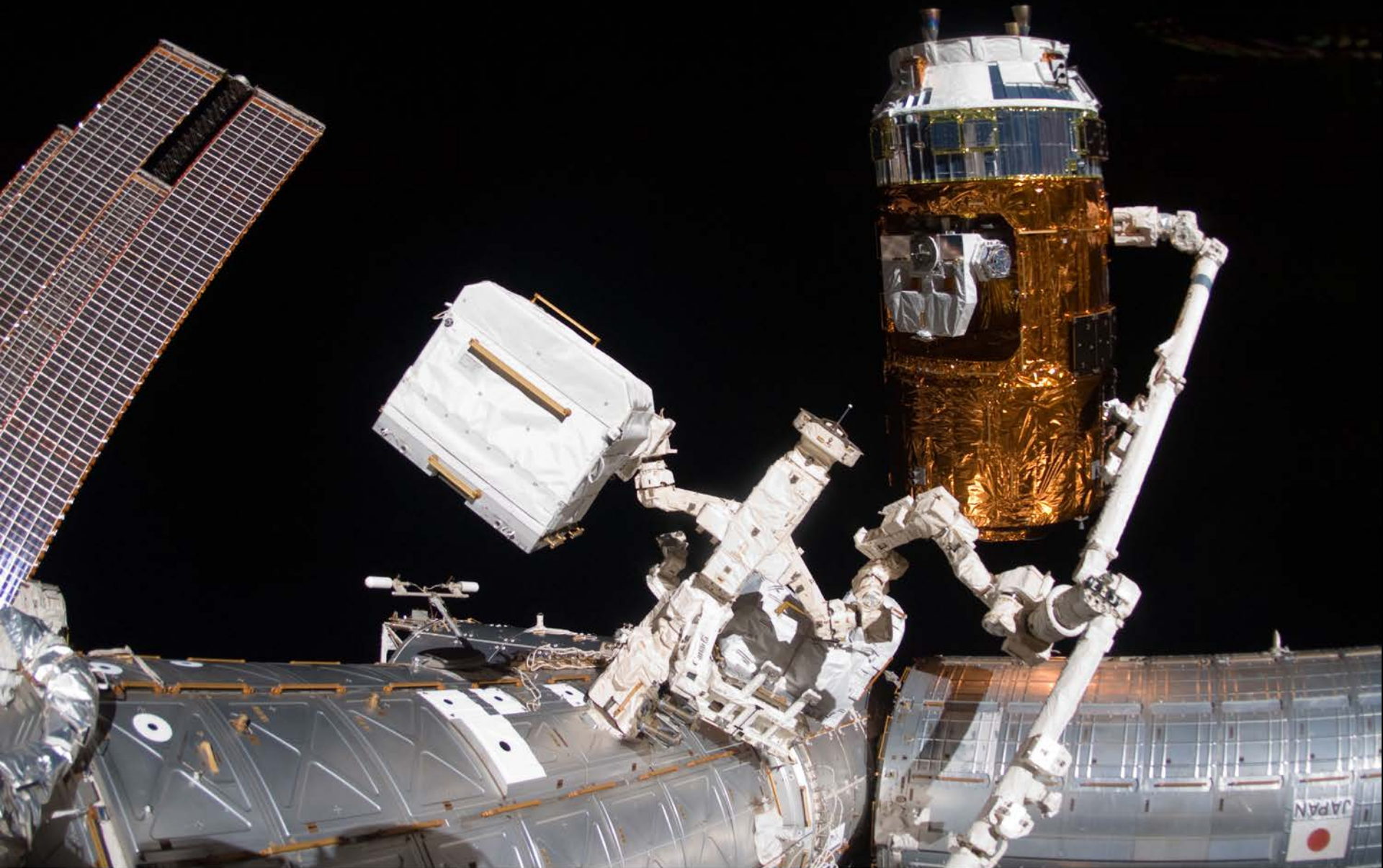

ISS026E028057

MANAGEMENT OPERATIONS CONTROL ARCHITECTURE (MOCA) MISSION STATUS

Alpha CubeSat Spacecraft Screen

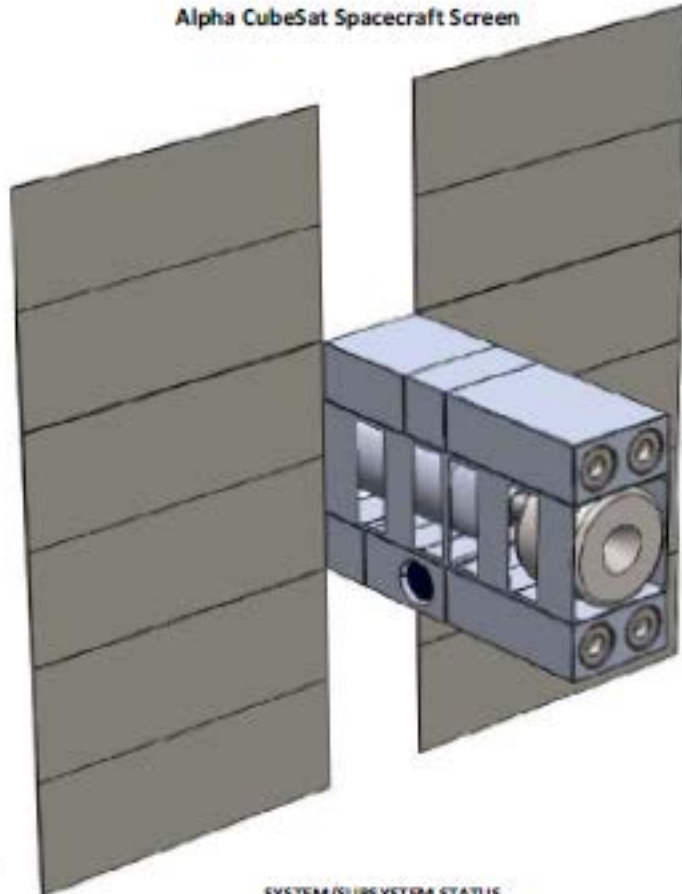

SYSTEM/SUBSYSTEM STATUS



PAYLOADS:



Alpha CubeSat Electrical Power System (EPS)

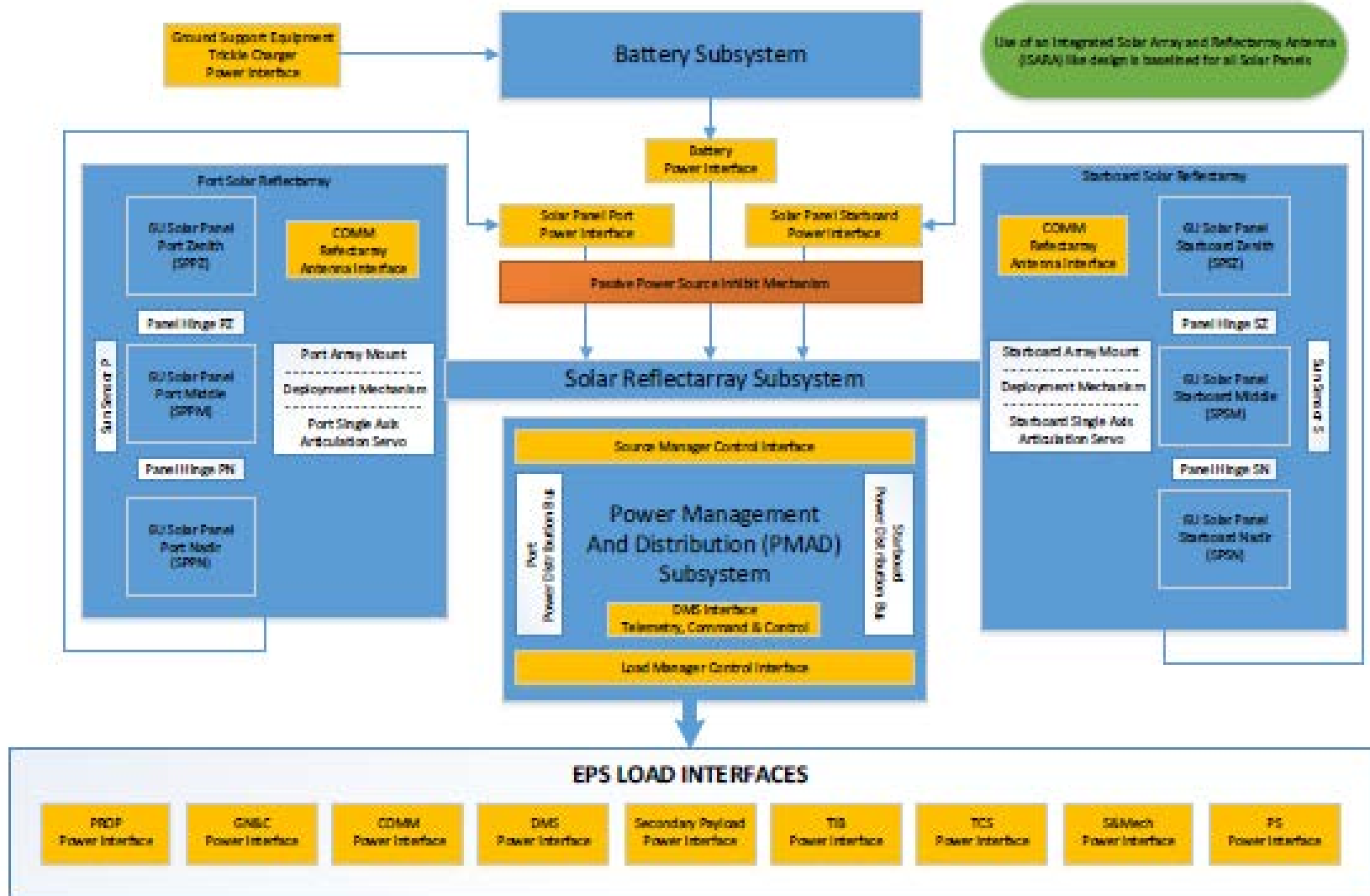

Alpha CubeSat Communications System (COMM)

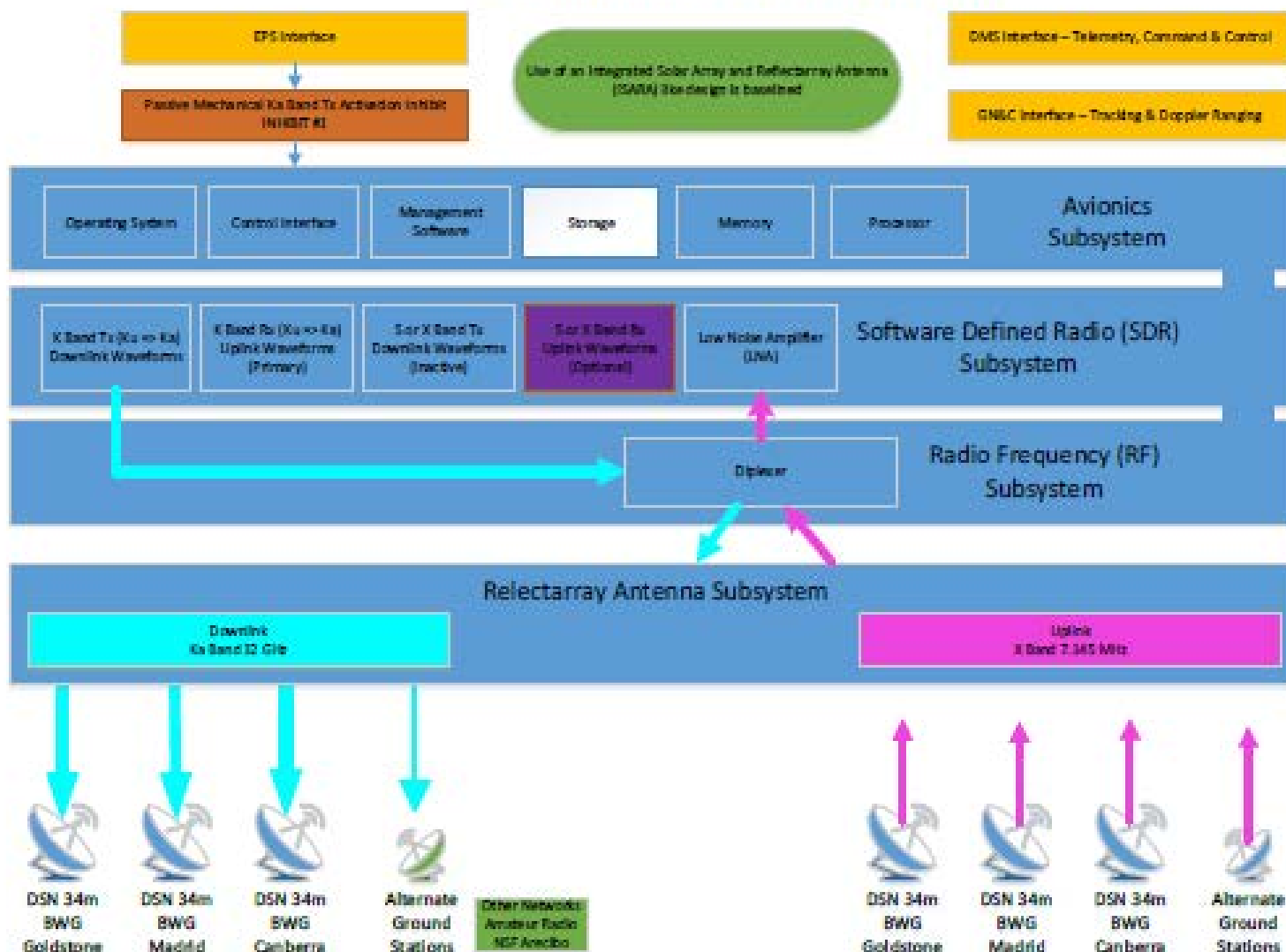

Alpha CubeSat Propulsion System (PROP)

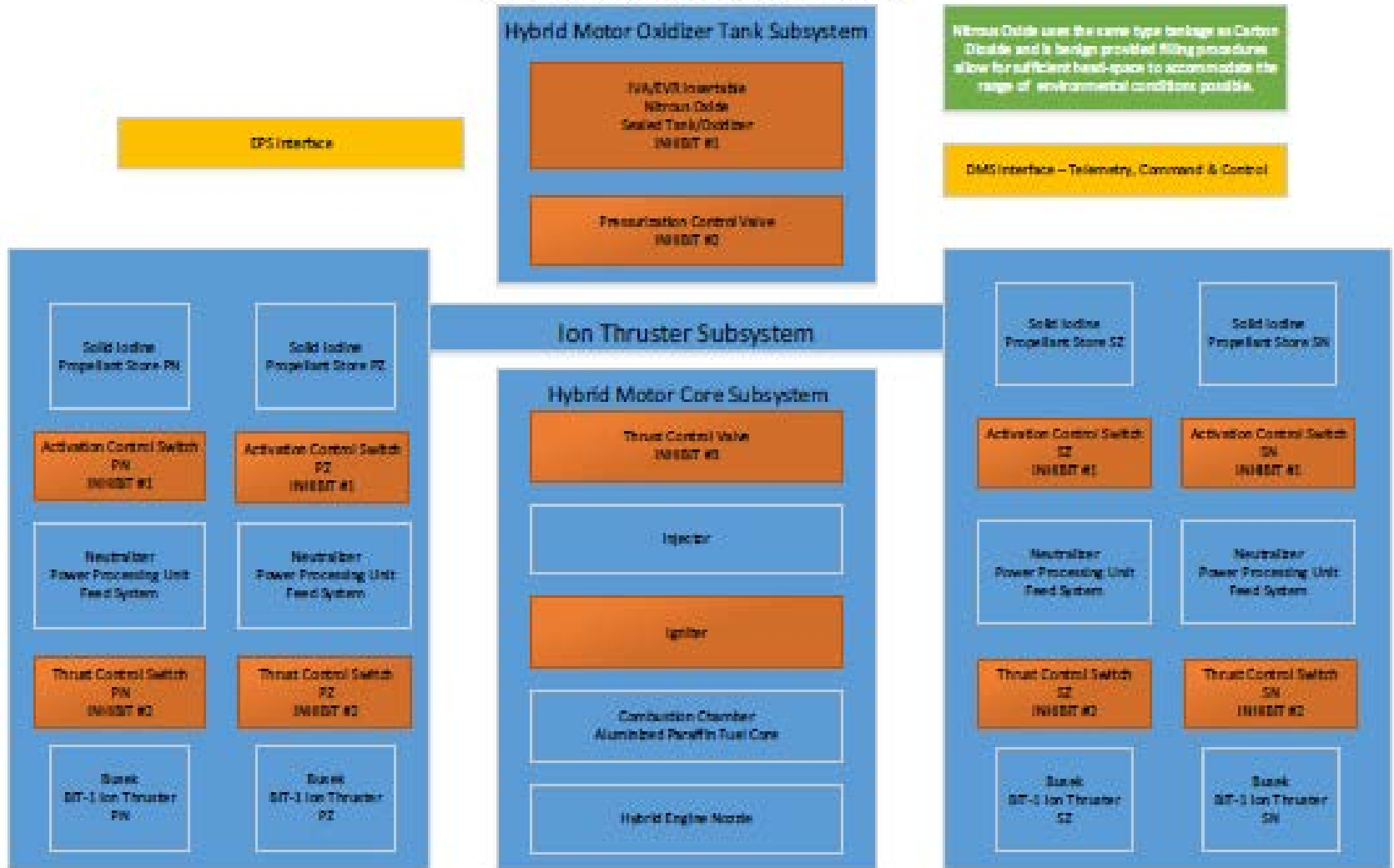

KEY:

- Baseline Subsystem (Blue box)
- Primary Interface (Yellow box)
- Safety Critical (Orange box)
- Highlight (Green box)

Alpha CubeSat Mode / State Transitions

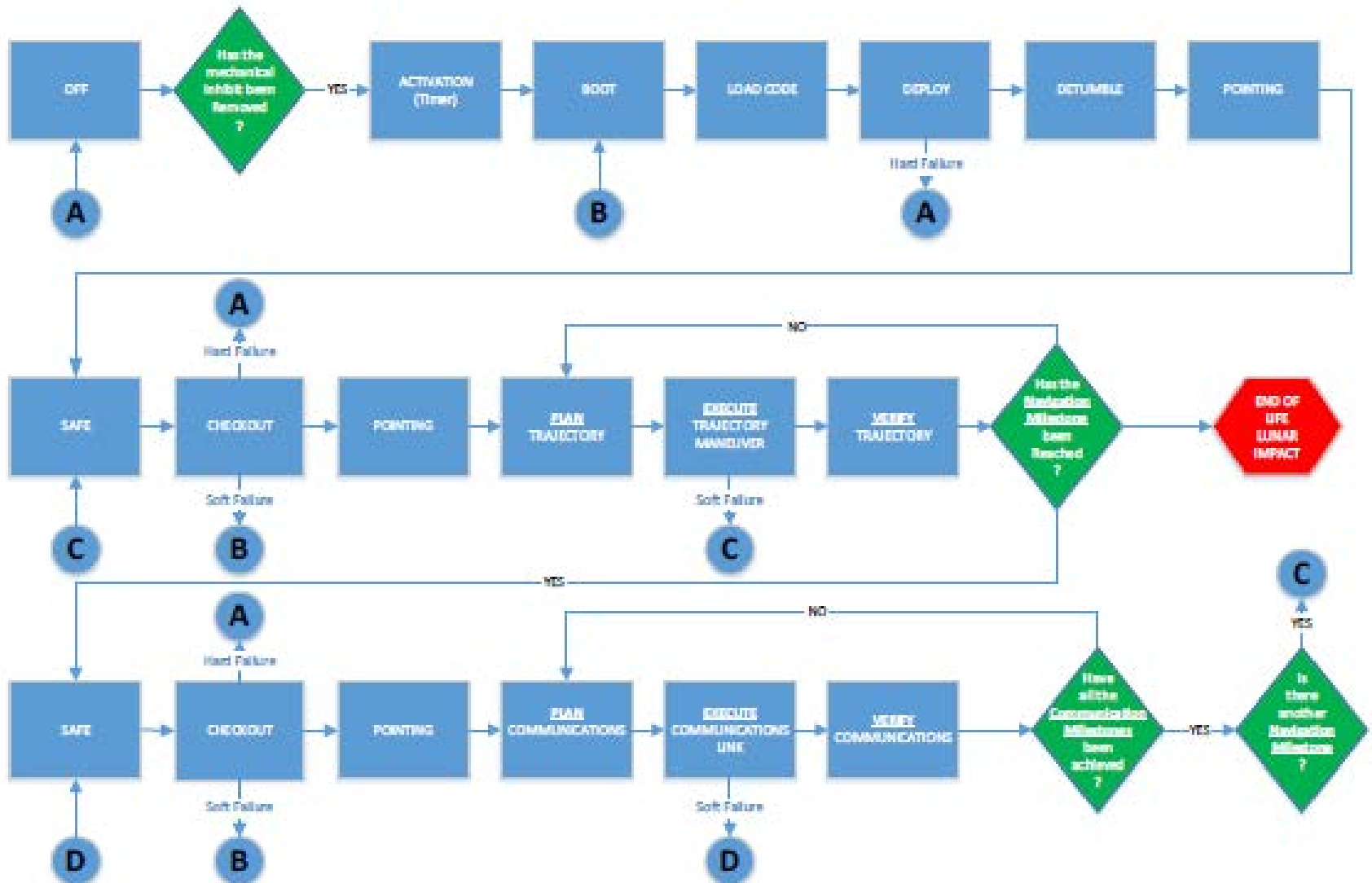

EVA Robotics & Crew . . .

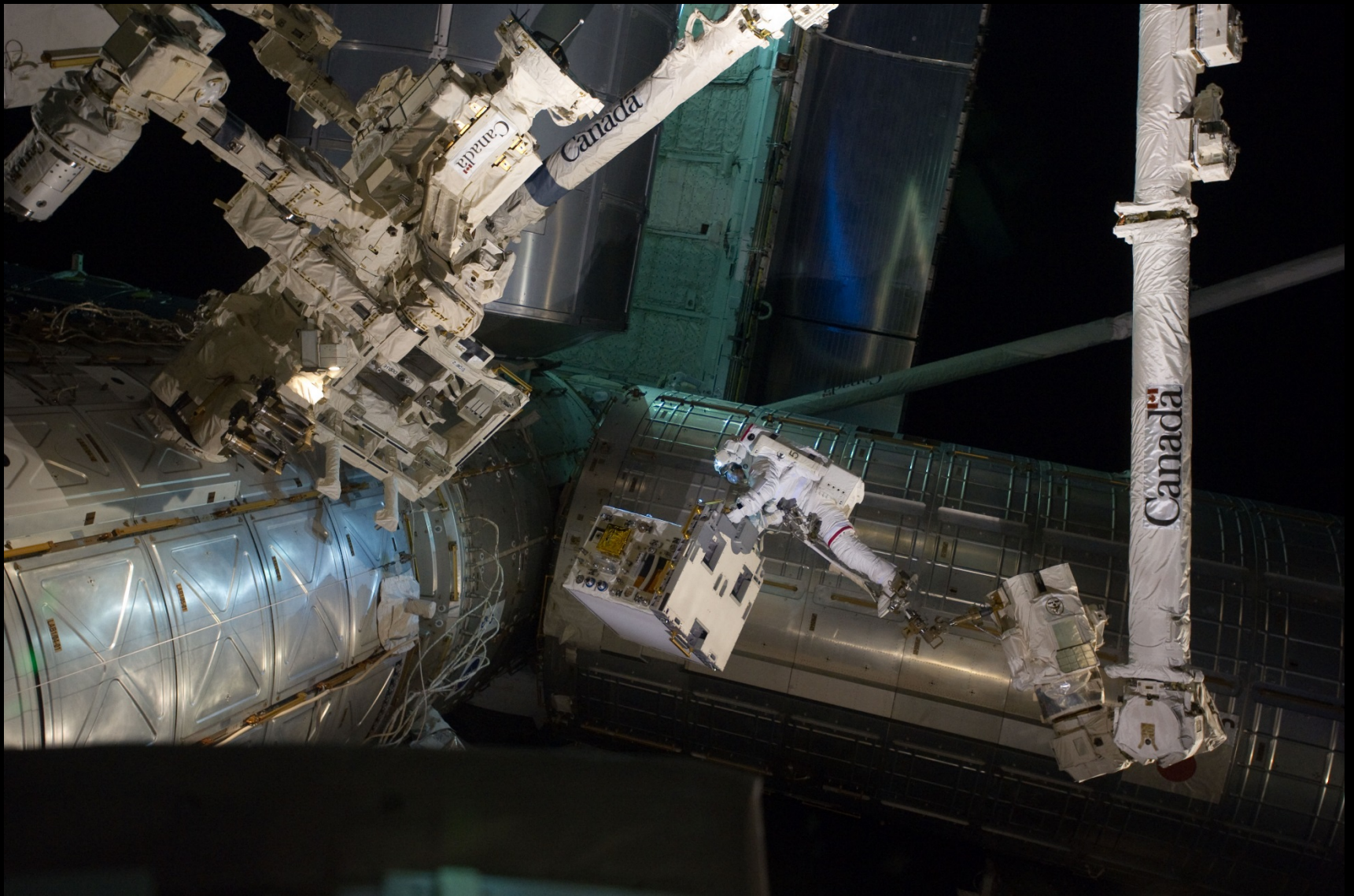

EVA Robotics . . .

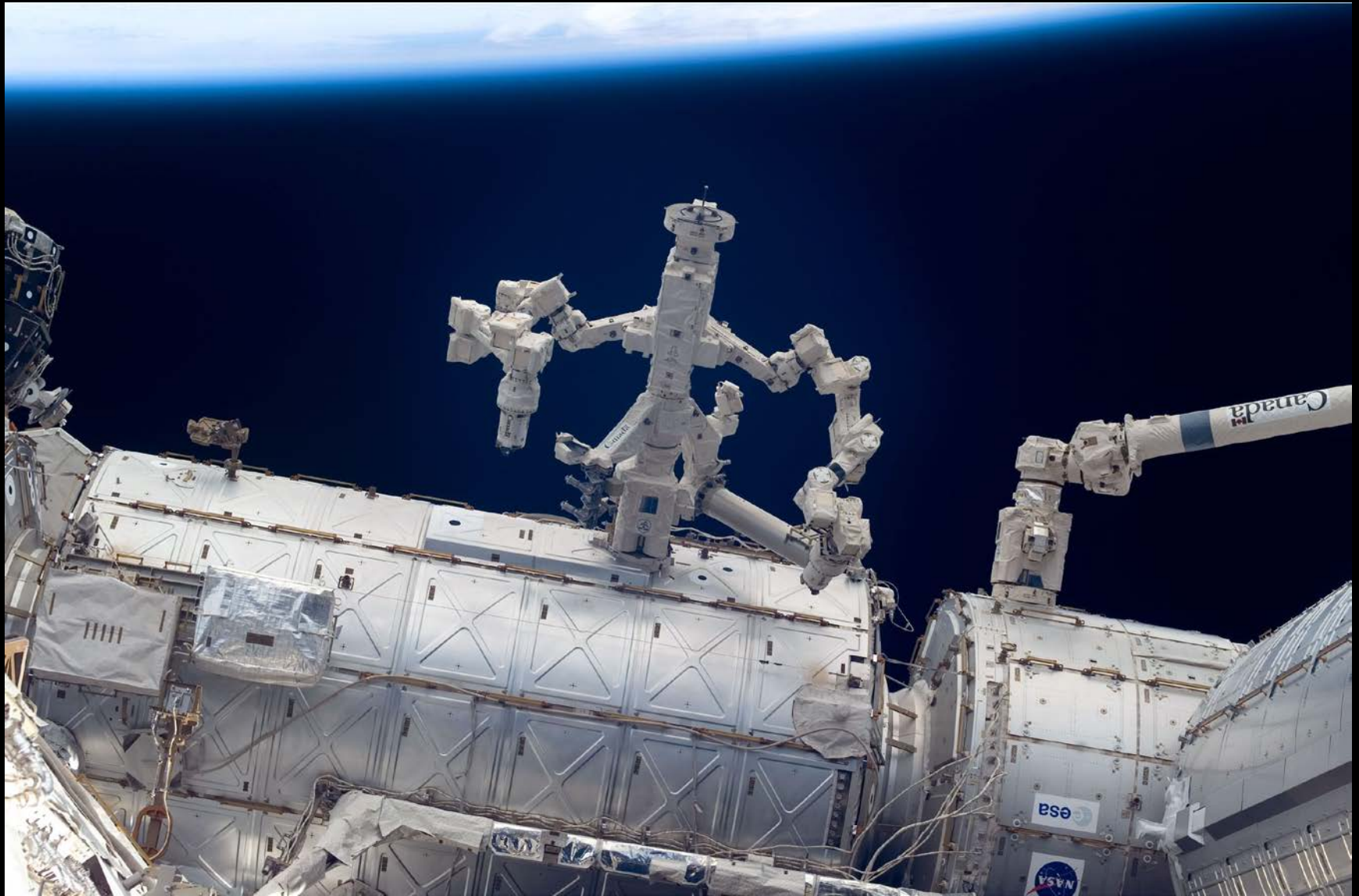

So you want to roam . . .

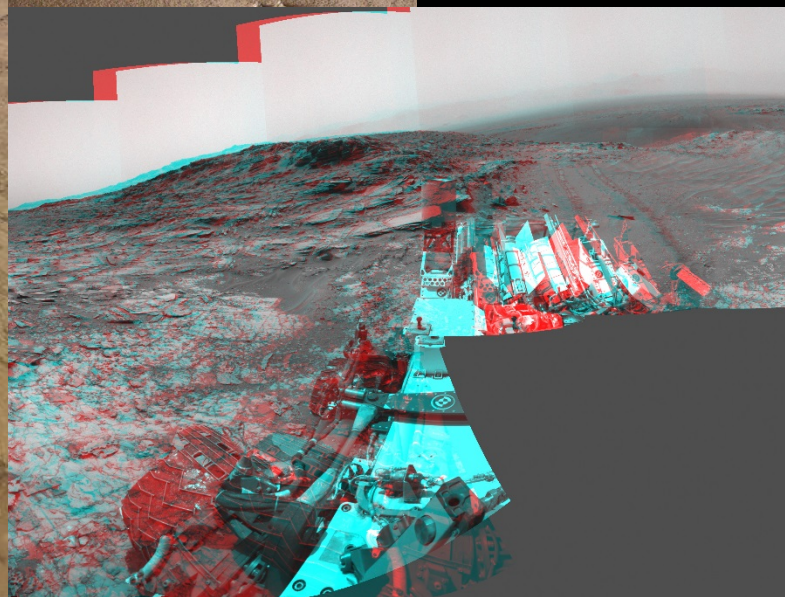

Going to Low Earth Orbit and Beyond . . .



So let's get real -- do you want to dance . . .

